

COMPONENTS	
COVER	WC20-2436-3TREI
BOX	WB23-2436-18

- MATERIAL: FIBERGLASS REINFORCED POLYMER CONCRETE & FIBERGLASS REINFORCED POLYMER
- COLOR: CONCRETE GRAY

NOTICE:
THIS DRAWING IS THE PROPERTY OF CDR SYSTEMS AND IS LOANED ONLY. ANY REPRODUCTION OR TRANSMISSION OF THIS DRAWING WITHOUT THE WRITTEN PERMISSION OF CDR SYSTEMS IS PROHIBITED.

REV 1 MKK 2/2/04

cdr SYSTEMS CORP
146 SOUTH ATLANTIC AVE., ORMOND BEACH, FL 32176

TITLE: **WA23-2436-18B-2TREI-0272**
PROPOSAL: **MIKE THOMPSON**

DRAWN	EGH	DATE	6/27/03
CHECKED			
APPROVED			

SIZE: **A** **031-0272**

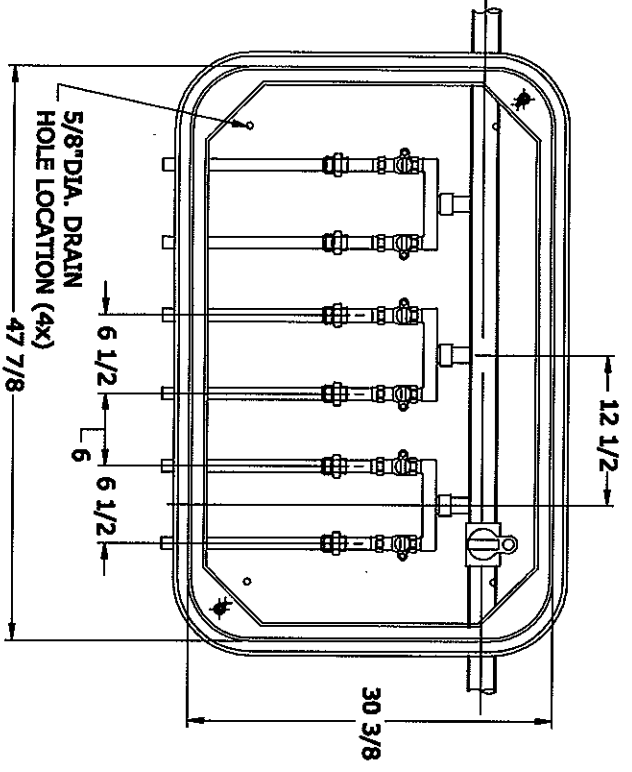

TOP VIEW

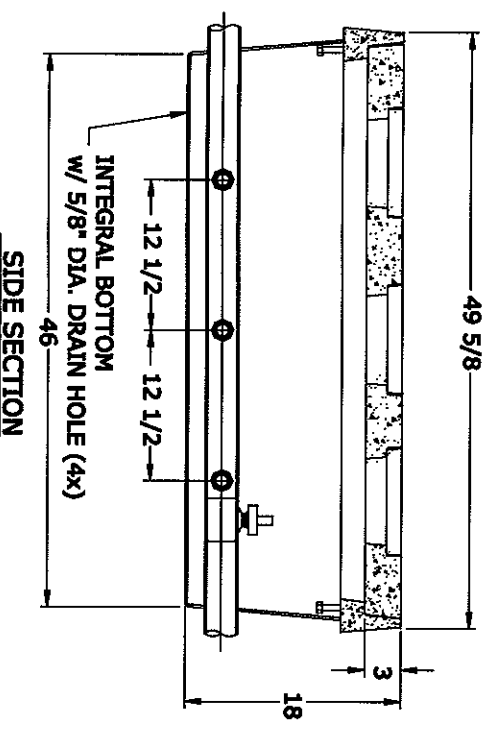

SIDE SECTION

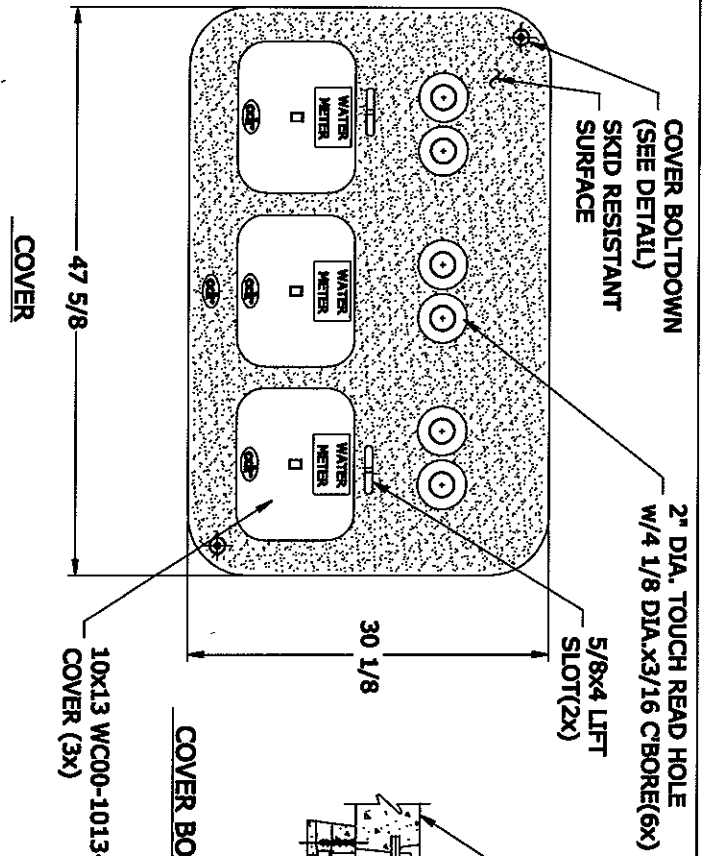

COVER BOLT-DOWN DETAIL

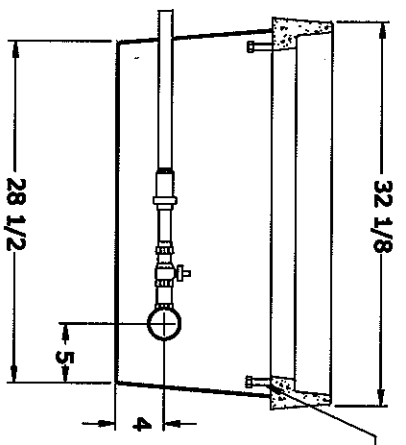
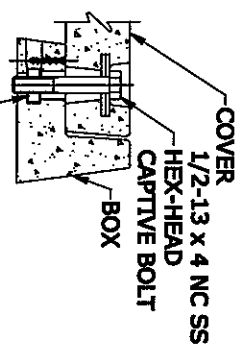

END SECTION

COMPONENTS	
COVER	WC20-3048-03-6TR
COVER	WC00-1013-02
BOX	WB23-3048-18W

- MATERIAL: FIBERGLASS REINFORCED POLYMER CONCRETE & FIBERGLASS REINFORCED POLYMER
- COLOR: CONCRETE GRAY

PART NO. **WA23-3048-18WBTR-0505**

30 X 48 X 18W WATER ASSEMBLY
w/ 6 TOUCH READ OPENINGS, INTEGRAL BOTTOM
AND WC00-1013-02 COVERS AS DROP IN LIDS

MIKE THOMPSON SALES

ITEM #

NOTICE
 This drawing is the property of CDR Systems and is loaned only upon the condition that it is not to be copied or reproduced for use by any other party without the written permission of CDR Systems. Any unauthorized use or reproduction is strictly prohibited and is subject to legal action.

REV 4 MMK 6/29/05

DATE: 6/30/03

DRN: JN

CHK'D:

APPR'VD:

DWG. NO.: **051-0505**

cds SYSTEMS CORP.
 146 SOUTH ATLANTIC AVE., ORMOND BEACH, FL 32176
 PHONE: (386) 615-9510 FAX: (386) 615-9606

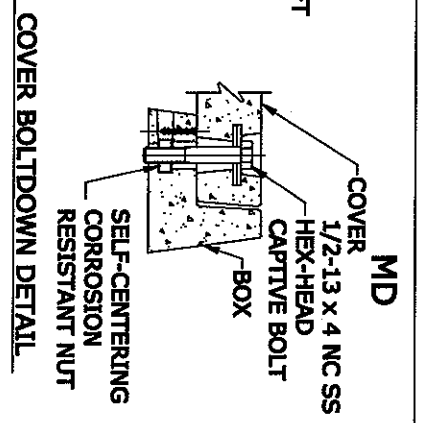
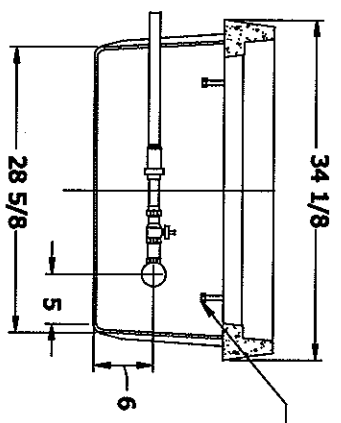
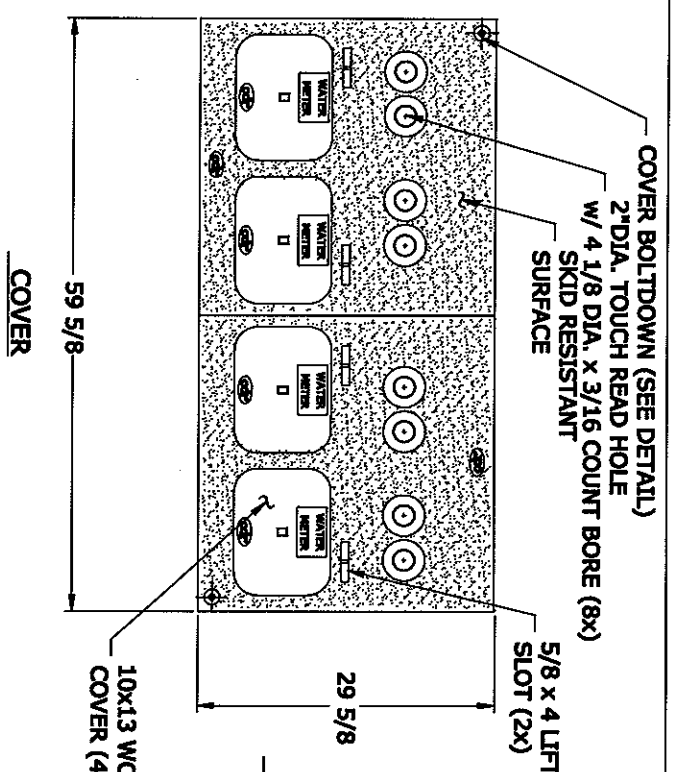
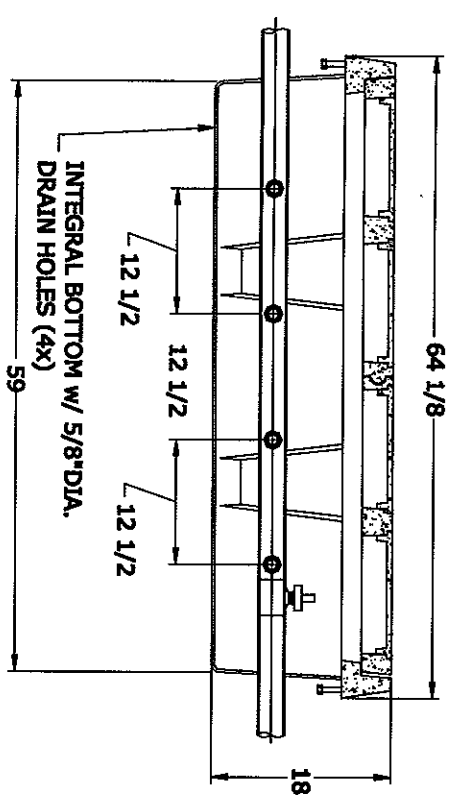
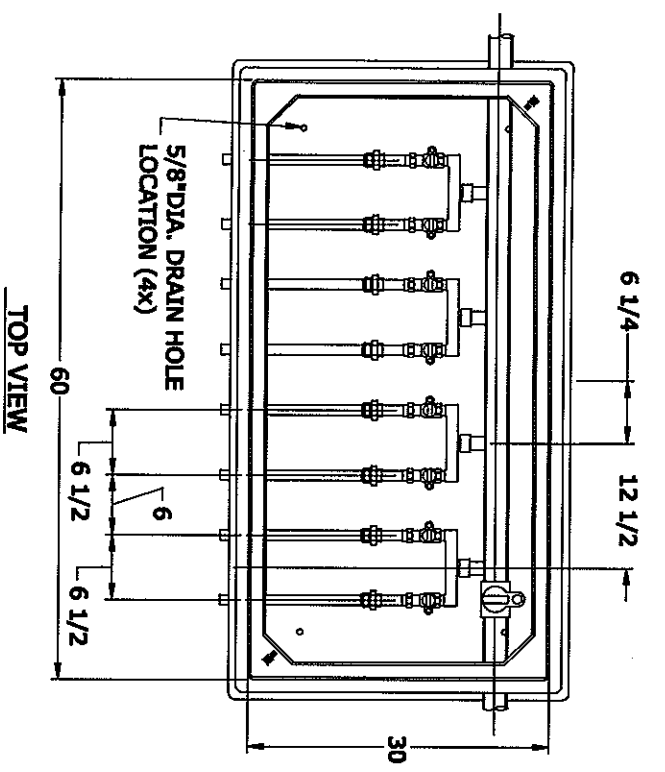

1/2\" DIA BOLT TO RETAIN LIFT SLING (4X)

COMPONENTS		
COVER	WC20-3060-23-8TR	
COVER	WC00-1013-02	
BOX	WB23-3060-18	

- MATERIAL: FIBERGLASS REINFORCED POLYMER CONCRETE & FIBERGLASS REINFORCED POLYMER
- COLOR: CONCRETE GRAY

ITEM #

NOTICE: This drawing is the property of CDR Systems and is loaned only upon the condition that it is not to be copied or reproduced nor to be used for marketing information to others or for any other purpose detrimental to the interest of CDR Systems.

REV 1 MMK 9/7/06

PART NO. **WA23-3060-18WBTR-0244**

30 X 60 X 18W WATER ASSEMBLY W/ 8 TOUCH READ OPENINGS, INTEGRAL BOTTOM AND WC00-1013-02 COVERS AS DROP IN LIDS

MIKE THOMPSON SALES

cdr SYSTEMS CORP.

146 SOUTH ATLANTIC AVE., ORMOND BEACH, FL 32176
PHONE: (386) 615-9510 FAX: (386) 615-9606

DATE: 11/30/05 DRN: JN CHK'D: APPR'D: DWG. NO.: **061-0244**

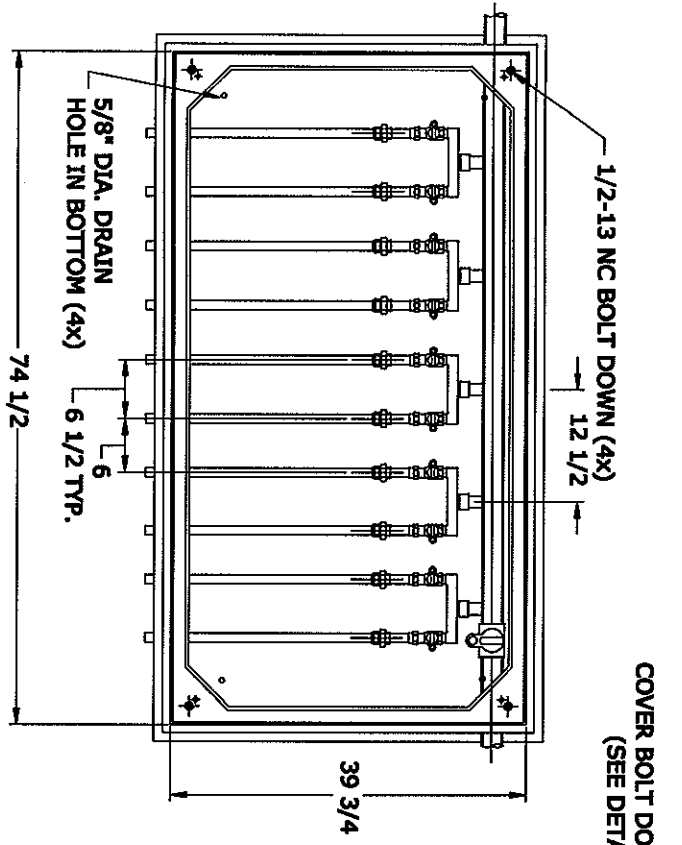

TOP VIEW

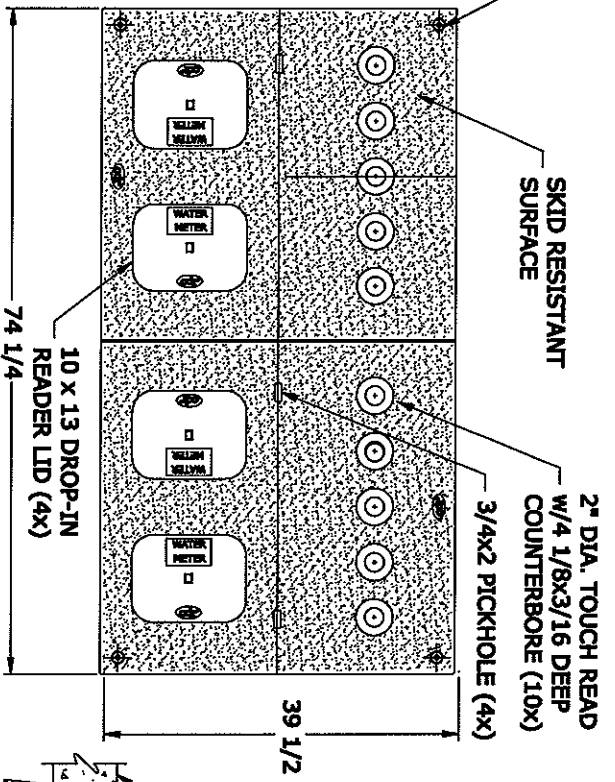

COVER BOLT DOWN DETAIL

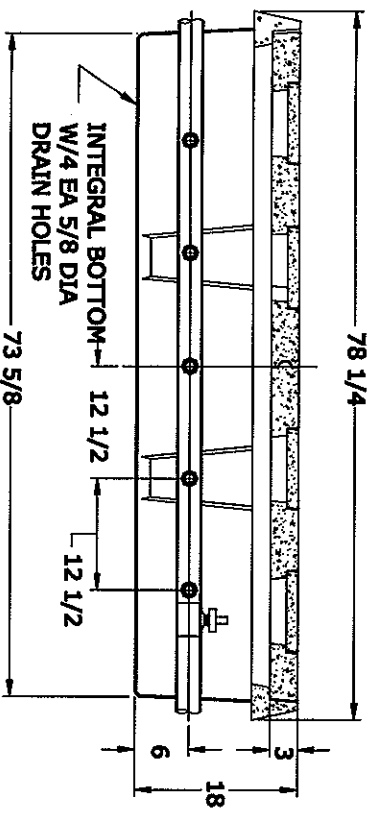

SIDE SECTION

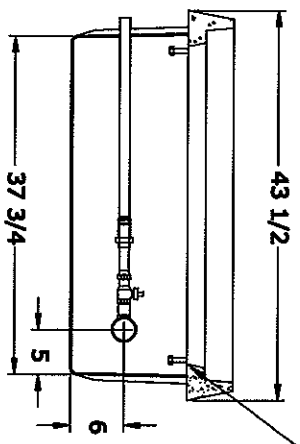

END VIEW

COMPONENTS	
COVER	WC20-3672-23-10TR
COVER	WC00-1013-02
BOX	WB23-3672-18W

- MATERIAL: FIBERGLASS REINFORCED POLYMER CONCRETE & FIBERGLASS REINFORCED POLYMER
- COLOR: CONCRETE GRAY

1/2" DIA. BOLT FOR SLING LIFTING (4x)

ITEM #

This drawing is the property of CDR Systems and is loaned only to the purchaser for their use. It is not to be copied or reproduced nor to be used for any other purpose without the written permission of CDR Systems.

NOTICE: See cover for additional information.

REV 4 MMK 2/17/07

PART NO. **WA23-3672-18WBTR-0074**

36 X 72 X 18W WATER ASSEMBLY
W/ 10 TOUCH READ OPENINGS, INTEGRAL BOTTOM
AND WC00-1013-02 COVERS AS DROP-IN LIDS

MIKE THOMPSON SALES

cdr SYSTEMS CORP.
 146 SOUTH ATLANTIC AVE., ORMOND BEACH, FL 32176
 PHONE: (386) 615-9510 FAX: (386) 615-9606

DATE: 1/26/05 DRN: EGH

CHK'D: APPR'VD: DWG. NO.: **281-0074**